

Technical information

Falcon 2-60



Characteristics

- Supplied with two sealing bars as standard (front/rear)
- Double seal as standard (two sealing wires). Optional at no extra cost: Cut-off/Wide seal
- Easy-to-remove silicone holders for easy cleaning and maintenance.
- Pump maintenance and cleaning program.
- Digital time control with ten-program memory as standard
- Aluminium vacuum chamber and lid with viewing window
- Stainless steel casing
- Supplied with eight insert plates for a faster cycle and good product positioning.

Options

- 1-2 Cut-off seal
- Bi-Active seal
- Soft Air to protect the product and vacuum bag.
- Sensor control
- Advanced Control System (ACS)
- Liquid control
- Gas flush

Accessories

- Thermal label printer (only in combination with ACS)
- Inclined insert plate (for vacuum packing liquids and powders)
- Maintenance set for standard maintenance



Specs	Falcon 2-60
Chamber LxWxH (mm)	580x450x235
Machine LxWxH (mm)	900x1060x1179
Voltage	400V-3-50Hz 230V-3-50Hz 220V-3-60Hz 200V-3-50/60Hz
Pump capacity 50 Hz/60 Hz (m3)	63 / 76
Machine cycle 50 Hz/60 Hz (sec.)	13 - 27 / 11 - 24
Power (kW)	1,6 - 2,4
Weight (kg)	236
Net seal length (mm)	2 x 445
Sealing bar configuration - standard	

Dimensions mm

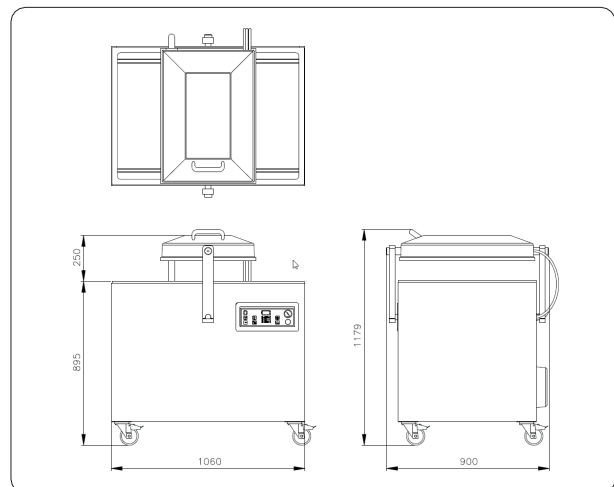

Henkelman Aust
Unit 3,14-16
Cairns Street, Loganholme
QLD Australia 4129
(07) 3806 5972

Sales/Service/Tech Support
sales@henkelman.com.au
Office Hours: 8am – 4pm
Open Monday - Friday